

M MF W P G UNC UNF



 **BUČOVICE  
TOOLS**

ZÁVITNÍKY  
TAPS  
GEWINDEBOHRER  
МЕТЧИКИ



Závítníky sadové / Set of hand taps / Satzgewindebohrer / Метчики наборные

Norma Standard Norm Стандарт	MATERIÁL / MATERIAL / MATERIAL / МАТЕРИАЛ													
	MAT	A	B	C	D	E	F	G	H	I	J	K	L	M
ČSN 22 3010	HSS	●	●	◐	●	◐	●	●	◐	◐	◐	○	◐	◐
	NO/CS	●	◐		◐	○	◐	◐	○	○	○		○	○
PN 8/3011	HSS	●	●	◐	●	◐	●	●	◐	◐	◐	○	◐	◐
	NO/CS	●	◐		◐	○	◐	◐	○	○	○		○	○
ČSN 22 3012	HSS	●	●	◐	●	◐	●	●	◐	◐	◐	○	◐	◐
	NO/CS	●	◐		◐	○	◐	◐	○	○	○		○	○
PN 8/3014	HSS	●	●	◐	●	◐	●	●	◐	◐	◐	○	◐	◐
	NO/CS	●	◐		◐	○	◐	◐	○	○	○		○	○
DIN 352	HSS	●	●	◐	●	◐	●	●	◐	◐	◐	○	◐	◐
	NO/CS	●	◐		◐	○	◐	◐	○	○	○		○	○
DIN 2181	HSS	●	●	◐	●	◐	●	●	◐	◐	◐	○	◐	◐
	NO/CS	●	◐		◐	○	◐	◐	○	○	○		○	○
PN 8/3015	HSS	●	●	◐	●	◐	●	●	◐	◐	◐	○	◐	◐
	NO/CS	●	◐		◐	○	◐	◐	○	○	○		○	○
V <sub>c</sub> m/min	HSS	6-10	2-8	2-6	2-6	2-4	2-6	2-4	5-8	6-10	12-18	5-8	10-15	10-15
	NO/CS	4-7	2-5		1-4	1-3	1-4	1-3	2-4	4-7	8-12		5-10	5-10
		1	1	1	1	1	1	1	1, 3	1, 3	1, 3	1, 3	2, 3	3

	INFORMACE - SYMBOLY	INFORMATION - NOTATION	INFORMATIONEN - BILDERE	ИНФОРМАЦИИ - СИМВОЛЫ
<b>NO/CS/WS</b>	nástrojová ocel	Carbon steel	Werkzeugstahl	Инструментальная сталь
<b>HSS</b>	výkonná rychlořezná ocel	High speed steel	Schnellschneidstahl	Сталь скоростной нарезки
<b>HSSE</b>	vysoce výkonná rychlořezná ocel	Super high speed steel	Höher legiertet Schnellschneidstahl	Сверх производительная быстрорежу - щаяся сталь
<b>ČSN</b>	česká norma	Czech standard	Tschechische Norm	Чешский стандарт
<b>PN</b>	podniková norma	Company standard	Betriebsnorm	Стандарт общефабричный
<b>LH</b>	levý závit	Left-hand thread	Gewinde links	Резьба левая
<b>TiN</b>	povlak nitridu titanu	Titanium nitride coating	Titannitrid-Beschichtung	TiN покрытие
<b>N</b>	nitridace	Nitration	Nitrieren	Нитридование
<b>OX</b>	oxidace	Oxidation	Oxidation	Оксидирование
<b>V<sub>c</sub></b>	řezná rychlost	Cutting speed	Schnittgeschwindigkeit	Скорость нарезки резьбы
	řezná kapalina	Cutting lubrication	Schneidflüssigkeit	Рекомендуемая жидкость
<b>S</b>	počet třískových otvorů	Number of clearance holes	Anzahl Spanlöcher	Количество зубьев в плашке
<b>VA</b>	na nerez	Stainless steel	Rostfreistähle	Нережавейка
	tloušťka plechu	Sheet thickness	Blechstärke	Толщина листа

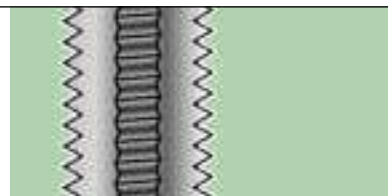

## Závitníky sadové Set of hand taps Satzgewindebohrer Метчики наборные

M

Metrický závit  
Standard metric thread  
Metrische Regelgewinde  
Метрическая резьба

MF

Jemný metrický závit  
Fine metric thread  
Metrische Feingewinde  
Мелкая метрическая резьба

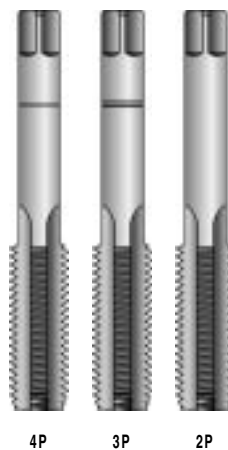
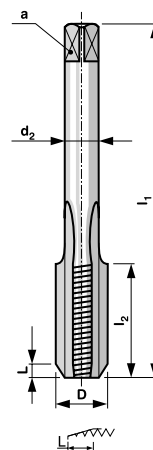
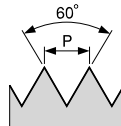
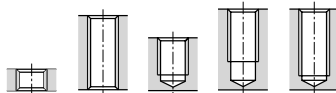

D	P	l <sub>1</sub>	l <sub>2</sub>	d <sub>2</sub>	a		*	code NO/CS	code HSS
M 2	0,4	34	8	2,5	2	1,6	3	110 020	140 020
M 2,2	0,45	34	9	2,8	2,24	1,75	3	110 022	140 022
M 2,5	0,45	34	10	2,8	2,24	2,05	3	110 025	140 025
M 2,5	0,35	28	8	2,8	2,24	2,15	2	110 026	140 026
M 3	0,5	36	10	3,15	2,5	2,5	3	110 030	140 030
M 3	0,35	32	8	3,15	2,5	2,65	2	110 031	140 031
M 3,5	0,6	36	12	3,55	2,8	2,9	3	110 035	140 035
M 3,5	0,35	32	9	3,55	2,8	3,15	2	110 036	140 036
M 4	0,7	41	14	4	3,15	3,3	3	110 040	140 040
M 4	0,5	38	11	4	3,15	3,5	2	110 041	140 041
M 4,5	0,5	38	11	4,5	3,55	4,0	2	110 046	140 046
M 5	0,8	45	16	5	4	4,2	3	110 050	140 050
M 5	0,5	40	11	5	4	4,5	2	110 051	140 051
M 5,5	0,5	40	12	5,6	4,5	5,0	2	110 056	140 056
M 6	1	50	17	4,5	3,55	5,0	3	110 060	140 060
M 6	0,75	44	15	4,5	3,55	5,2	2	110 061	140 061
M 7	1	50	17	5,6	4,5	6,0	3	110 070	140 070
M 7	0,75	44	15	5,6	4,5	6,2	2	110 071	140 071
M 8	1,25	54	22	6	5	6,8	3	110 080	140 080
M 8	1	46	16	6	5	7,0	2	110 081	140 081
M 8	0,75	44	16	6	5	7,2	2	110 082	140 082
M 9	1,25	60	22	7,1	5,6	7,8	3	110 090	140 090
M 9	1	52	17	7,1	5,6	8,0	2	110 091	140 091
M 9	0,75	50	17	7,1	5,6	8,2	2	110 092	140 092
M 10	1,5	63	25	7,1	5,6	8,5	3	110 100	140 100
M 10	1,25	56	18	7,1	5,6	8,8	2	110 101	140 101
M 10	1	56	18	7,1	5,6	9,0	2	110 102	140 102
M 10	0,75	56	18	7,1	5,6	9,2	2	110 103	140 103
M 11	1,5	63	28	8	6,3	9,5	3	110 110	140 110
M 11	1	56	20	8	6,3	10,0	2	110 111	140 111
M 11	0,75	56	20	8	6,3	10,2	2	110 112	140 112
M 12	1,75	70	30	9	7,1	10,2	3	110 120	140 120
M 12	1,5	63	25	9	7,1	10,5	2	110 121	140 121
M 12	1,25	60	22	9	7,1	10,8	2	110 122	140 122
M 12	1	60	22	9	7,1	11,0	2	110 123	140 123
M 14	2	80	30	11	9	12,0	3	110 140	140 140
M 14	1,5	70	28	11	9	12,5	2	110 141	140 141
M 14	1,25	63	25	11	9	12,8	2	110 142	140 142
M 14	1	63	25	11	9	13,0	2	110 143	140 143
M 15	1	70	25	11	9	14,0	2	110 152	140 152
M 16	2	80	35	12,5	10	14,0	3	110 160	140 160
M 16	1,5	70	28	12,5	10	14,5	2	110 161	140 161
M 16	1	70	25	12,5	10	15,0	2	110 162	140 162
M 17	1	70	28	12,5	10	16,0	2	110 171	140 171
M 18	2,5	90	36	14	11,2	15,5	3	110 180	140 180
M 18	1,5	80	32	14	11,2	16,5	2	110 181	140 181
M 18	1	70	28	14	11,2	17,0	2	110 182	140 182
M 20	2,5	90	36	14	11,2	17,5	3	110 200	140 200
M 20	1,5	80	32	14	11,2	18,5	2	110 201	140 201
M 20	1	75	28	14	11,2	19,0	2	110 202	140 202
M 22	2,5	90	40	16	12,5	19,5	3	110 220	140 220
M 22	1,5	80	32	16	12,5	20,5	2	110 221	140 221
M 22	1	75	28	16	12,5	21,0	2	110 222	140 222
M 24	3	100	45	18	14	21,0	3	110 240	140 240
M 24	2	90	36	18	14	22,0	2	110 241	140 241
M 24	1,5	85	32	18	14	22,5	2	110 242	140 242
M 24	1	80	28	18	14	23,0	1	110 243	140 243
M 25	1,5	90	32	18	14	23,5	2	110 252	140 252
M 26	1,5	90	32	18	14	24,5	2	110 262	140 262
M 27	3	100	45	20	16	24	3	110 270	140 270

Materiál: NO; HSS  
Provedení: nebrošený závit  
Závit: pravý, levý - dle požadavku  
Licování: 2N

Material: CS; HSS  
Execution: non-ground thread  
Thread: right-hand, left-hand on request  
Tolerance: 2N

Werkstoff: WS; HSS  
Ausführung: nicht geschliffenes Gewinde  
Gewinde: rechts, links - nach dem Anspruch  
Toleranz: 2N

Материал: NO; HSS  
Изготовлено: нешлифованная резьба  
Резьба: правая, левая - по заказу  
Подгонка: 2N

## Závitníky sadové Set of hand taps Satzgewindebohrer Метчики наборные

**M**

Metrický závit  
Standard metric thread  
Metrische Regelgewinde  
Метрическая резьба

**MF**

Jemný metrický závit  
Fine metric thread  
Metrische Feingewinde  
Мелкая метрическая резьба

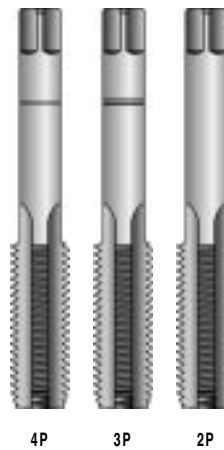
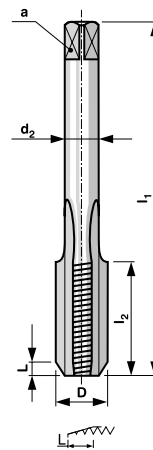
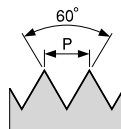
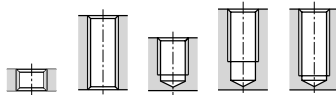

D	P	l <sub>1</sub>	l <sub>2</sub>	d <sub>2</sub>	a		*	code NO/CS	code HSS
M 27	2	90	36	20	16	25	2	110 271	140 271
M 27	1,5	90	32	20	16	25,5	2	110 272	140 272
M 27	1	85	28	20	16	26	1	110 273	140 273
M 28	2	100	36	20	16	26	2	110 281	140 281
M 28	1,5	90	32	20	16	26,5	2	110 282	140 282
M 30	3,5	120	50	20	16	26,5	3	110 300	140 300
M 30	2	100	36	20	16	28	2	110 301	140 301
M 30	1,5	100	32	20	16	28,5	2	110 302	140 302
M 30	1	85	32	20	16	29	1	110 303	140 303

\* kusy v sadě / pcs in set / Stck in Satz / штук в наборе

*Material: NO; HSS  
Provedení: nebroušený závit  
Závit: pravý, levý - dle požadavku  
Licování: 2N*

*Material: CS; HSS  
Execution: non-ground thread  
Thread: right-hand, left-hand on request  
Tolerance: 2N*

*Werkstoff: WS; HSS  
Ausführung: nicht geschliffenes Gewinde  
Gewinde: rechts, links - nach dem Anspruch  
Toleranz: 2N*

*Material: NO; HSS  
Изготовлено: нешлифованная резьба  
Резьба: правая, левая - по заказу  
Подгонка: 2N*

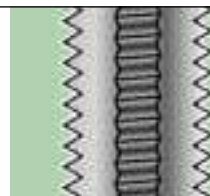

NO

CS

HSS



**BUČOVICE TOOLS**

## Závitníky sadové Set of hand taps Satzgewindebohrer Метчики наборные

W

Whitworthův závit  
Whitworth thread  
Whitworth-Gewinde  
Резьба Витворта

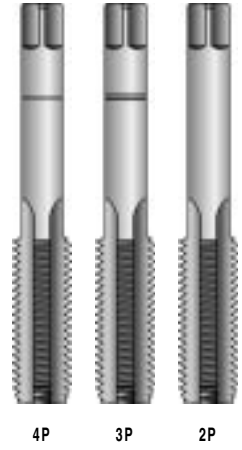
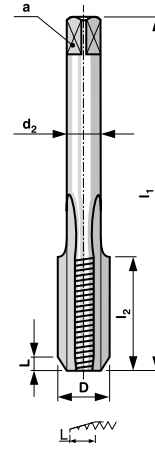
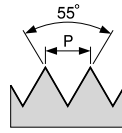
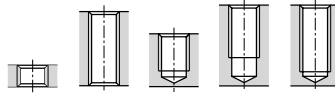

D	z/1"	P	l <sub>1</sub>	l <sub>2</sub>	d <sub>2</sub>	a		*	code NO/CS	code HSS
W 3/32"	48	0,529	34	10	3,15	2,5	1,75	3	111 332	141 332
W 1/8"	40	0,635	37	12	4	3,15	2,4	3	111 180	141 180
W 5/32"	32	0,794	41	14	5	4	3,0	3	111 532	141 532
W 3/16"	24	1,058	44	18	5	4	3,5	3	111 316	141 316
W 7/32"	24	1,058	44	18	5,6	4,5	4,3	3	111 732	141 732
W 1/4"	20	1,270	48	22	6,3	5	4,9	3	111 140	141 140
W 5/16"	18	1,411	51	26	5,6	4,5	6,4	3	111 516	141 516
W 3/8"	16	1,588	60	26	7,1	5,6	7,7	3	111 380	141 380
W 7/16"	14	1,814	60	28	8	6,3	9,1	3	111 716	141 716
W 1/2"	12	2,117	70	32	9	7,1	10,3	3	111 120	141 120
W 9/16"	12	2,117	70	32	9	7,1	11,8	3	111 916	141 916
W 5/8"	11	2,309	80	36	12,5	10	13,25	3	111 580	141 580
W 3/4"	10	2,540	90	40	14	11,2	16,25	3	111 340	141 340
W 7/8"	9	2,822	100	45	18	14	19	3	111 780	141 780
W 1"	8	3,175	110	45	20	16	21,75	3	111 100	141 100

\* kusy v sadě / pcs in set / Stck in Satz / штук в наборе

*Materiál: NO; HSS  
Provedení: nebroušený závit  
Licování: střední*

*Materiál: CS; HSS  
Execution: non-ground thread  
Tolerance: medium*

*Werkstoff: WS; HSS  
Ausführung: nicht geschliffenes  
Gewinde  
Toleranz: mittel*

*Материал: NO; HSS  
Изготовлено: нешлифованная резьба  
Подгонка: средний класс*

NO

CS

HSS



**BUČOVICE TOOLS**

## Závitníky sadové Set of hand taps Satzgewindebohrer Метчики наборные

G

Trubkový závit  
Pipe thread  
Rohrgewinde  
Трубная резьба

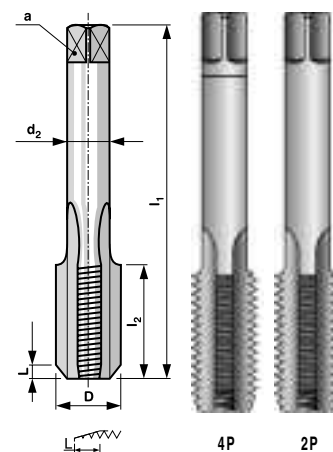
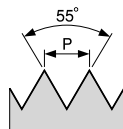
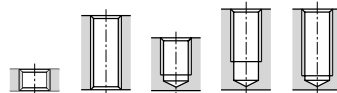

D	z/1"	P	l <sub>1</sub>	l <sub>2</sub>	d <sub>2</sub>	a		*	code NO/CS	code HSS
G 1/16"	28	0,907	52	14	5,6	4,5	6,7	2	112 116	142 116
G 1/8"	28	0,907	59	15	8	6,3	8,8	2	112 180	142 180
G 1/4"	19	1,337	67	19	10	8	11,7	2	112 140	142 140
G 3/8"	19	1,337	75	21	12,5	10	15,2	2	112 380	142 380
G 1/2"	14	1,814	87	26	16	12,5	18,8	2	112 120	142 120
G 5/8"	14	1,814	91	26	18	14	20,75	2	112 580	142 580
G 3/4"	14	1,814	96	28	20	16	24,25	2	112 340	142 340
G 7/8"	14	1,814	102	29	22,4	18	28	2	112 780	142 780
G 1"	11	2,309	109	33	25	20	30,5	2	112 100	142 100

\* kusy v sadě / pcs in set / Stck in Satz / штук в наборе

*Material: NO; HSS*

*Provedení: nebroušený závit*

*Licování: A*

*Material: CS; HSS*

*Execution: non-ground thread*

*Tolerance: A*

*Werkstoff: WS; HSS*

*Ausführung: nicht geschliffenes*

*Gewinde*

*Toleranz: A*

*Material: NO; HSS*

*Изготовлено: нешлифованная резьба*

*Подгонка: A*

# PN 8/3014

NO

CS



**BUČOVICE TOOLS**

## Závitníky sadové Set of hand taps Satzgewindebohrer Метчики наборные

P

Pancéřový závit  
Steel conduit thread  
Stahlpanzerrohr-Gewinde  
Панцирная резьба

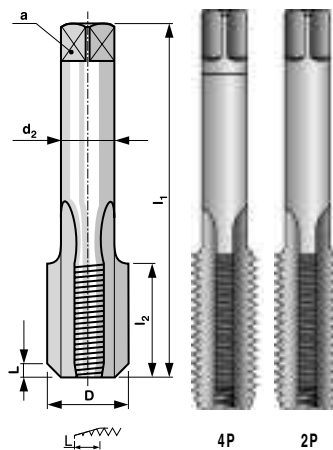
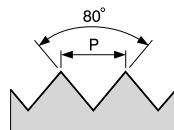
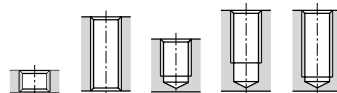

D	z/1"	P	l <sub>1</sub>	l <sub>2</sub>	d <sub>2</sub>	a		*	code NO/CS
P 7	20	1,270	63	28	9	7,1	11,3	2	113 070
P 9	18	1,411	70	28	10	8	13,8	2	113 090
P 11	18	1,411	80	32	12,5	10	17,2	2	113 110
P 13,5	18	1,411	80	32	16	12,5	19,0	2	113 135
P 16	18	1,411	85	32	18	14	21,0	2	113 160
P 21	16	1,588	90	36	20	16	26,75	2	113 210

\* kusy v sadě / pcs in set / Stck in Satz / штук в наборе

*Material: NO*

*Provedení: nebroušený závit*

*Material: CS*

*Execution: non-ground thread*

*Werkstoff: WS*

*Ausführung: nicht geschliffenes*

*Gewinde*

*Material: NO*

*Изготовлено: нешлифованная резьба*

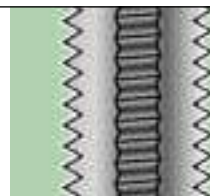

**Závitníky sadové**  
**Set of hand taps**  
**Satzgewindebohrer**  
**Метчики наборные**

**M**

Metrický závit  
Standard metric thread  
Metrische Regelgewinde  
Метрическая резьба

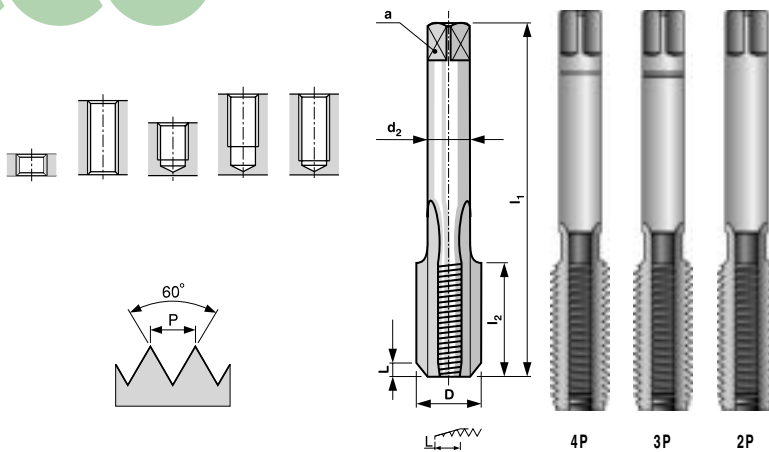

D	P	l <sub>1</sub>	l <sub>2</sub>	d <sub>2</sub>	a		*	code NO/CS	code HSS
M 2	0,4	36	8	2,8	2,1	1,60	3	114 020	144 020
M 2,2	0,45	36	9	2,8	2,1	1,75	3	114 022	144 022
M 2,5	0,45	40	9	2,8	2,1	2,05	3	114 025	144 025
M 3	0,5	40	11	3,5	2,7	2,50	3	114 030	144 030
M 3,5	0,6	45	13	4	3	2,9	3	114 035	144 035
M 4	0,7	45	13	4,5	3,4	3,3	3	114 040	144 040
M 4,5	0,75	50	16	6	4,9	4,0	3	114 045	144 045
M 5	0,8	50	16	6	4,9	4,2	3	114 050	144 050
M 6	1	50	19	6	4,9	5,0	3	114 060	144 060
M 7	1	50	19	6	4,9	6,0	3	114 070	144 070
M 8	1,25	56	22	6	4,9	6,8	3	114 080	144 080
M 9	1,25	63	22	7	5,5	7,8	3	114 090	144 090
M 10	1,5	70	24	7	5,5	8,5	3	114 100	144 100
M 11	1,5	70	24	8	6,2	9,5	3	114 110	144 110
M 12	1,75	75	29	9	7	10,2	3	114 120	144 120
M 14	2	80	30	11	9	12,0	3	114 140	144 140
M 16	2	80	32	12	9	14,0	3	114 160	144 160
M 18	2,5	95	40	14	11	15,5	3	114 180	144 180
M 20	2,5	95	40	16	12	17,5	3	114 200	144 200
M 22	2,5	100	40	18	14,5	19,5	3	114 220	144 220
M 24	3	110	50	18	14,5	21,0	3	114 240	144 240
M 27	3	110	50	20	16	24	3	114 270	144 270
M 30	3,5	125	56	22	18	26,5	3	114 300	144 300

\* kusy v sadě / pcs in set / Stck in Satz / штук в наборе

*Materiál: NO; HSS  
Provedení: nebroušený závit  
Závit: pravý, levý - dle  
požadavku  
Licování: 2N*

*Material: CS; HSS  
Execution: non-ground thread  
Thread: right-hand, left-hand -  
on request  
Tolerance: 2N*

*Werkstoff: WS; HSS  
Ausführung: nicht geschliffenes  
Gewinde  
Gewinde: rechts, links - nach  
dem Anspruch  
Toleranz: 2N*

*Материал: NO; HSS  
Изготовлено:  
нешлифованная резьба  
Резьба: правая, левая - по  
заказу  
Подгонка: 2N*

## Závitníky sadové Set of hand taps Satzgewindebohrer Метчики наборные

MF

Jemný metrický závit  
Fine metric thread  
Metrische Feingewinde  
Мелкая метрическая резьба

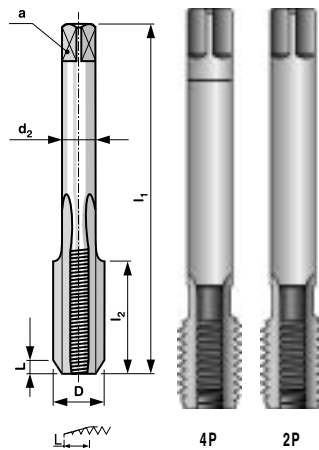
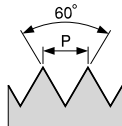
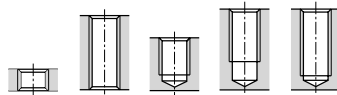

D	P	l <sub>1</sub>	l <sub>2</sub>	d <sub>2</sub>	a		*	code NO/CS	code HSS
M 2,5	0,35	40	9	2,8	2,1	2,15	2	114 026	144 026
M 3	0,35	40	9	3,5	2,7	2,65	2	114 031	144 031
M 3,5	0,35	45	10	4,0	3,0	3,15	2	114 036	144 036
M 4	0,5	45	10	4,5	3,4	3,50	2	114 041	144 041
M 4,5	0,5	50	12	6,0	4,9	4,0	2	114 046	144 046
M 5	0,5	50	12	6,0	4,9	4,5	2	114 051	144 051
M 5,5	0,5	50	12	6,0	4,9	5,0	2	114 056	144 056
M 6	0,75	50	14	6,0	4,9	5,2	2	114 061	144 061
M 7	0,75	50	14	6,0	4,9	6,2	2	114 071	144 071
M 8	1	56	22	6,0	4,9	7,0	2	114 081	144 081
M 8	0,75	50	19	6,0	4,9	7,2	2	114 082	144 082
M 9	1	63	22	7,0	5,5	8,0	2	114 091	144 091
M 9	0,75	56	19	7,0	5,5	8,2	2	114 092	144 092
M 10	1,25	70	24	7,0	5,5	8,8	2	114 101	144 101
M 10	1	63	20	7,0	5,5	9,0	2	114 102	144 102
M 10	0,75	63	20	7,0	5,5	9,2	2	114 103	144 103
M 11	1	63	20	8,0	6,2	10,0	2	114 111	144 111
M 11	0,75	63	20	8,0	6,2	10,2	2	114 112	144 112
M 12	1,5	70	22	9,0	7,0	10,5	2	114 121	144 121
M 12	1,25	70	22	9,0	7,0	10,8	2	114 122	144 122
M 12	1	70	22	9,0	7,0	11,0	2	114 123	144 123
M 14	1,5	70	22	11	9,0	12,5	2	114 141	144 141
M 14	1,25	70	22	11	9,0	12,8	2	114 142	144 142
M 14	1	70	22	11	9,0	13,0	2	114 143	144 143
M 15	1	70	22	12	9,0	14,0	2	114 152	144 152
M 16	1,5	70	22	12	9,0	14,5	2	114 161	144 161
M 16	1	70	22	12	9,0	15,0	2	114 162	144 162
M 17	1	70	22	12	9,0	16,0	2	114 171	144 171
M 18	1,5	80	22	14	11,0	16,5	2	114 181	144 181
M 18	1	80	22	14	11,0	17,0	2	114 182	144 182
M 20	1,5	80	22	16	12,0	18,5	2	114 201	144 201
M 20	1	80	22	16	12,0	19,0	2	114 202	144 202
M 22	1,5	80	22	18	14,5	20,5	2	114 221	144 221
M 22	1	80	22	18	14,5	21,0	2	114 222	144 222
M 24	2	90	22	18	14,5	22,0	2	114 241	144 241
M 24	1,5	90	22	18	14,5	22,5	2	114 242	144 242
M 24	1	90	22	18	14,5	23,0	2	114 243	144 243
M 25	1,5	90	22	18	14,5	23,5	2	114 252	144 252
M 26	1,5	90	22	18	14,5	24,5	2	114 262	144 262
M 27	2	90	22	20	16	25	2	114 271	144 271
M 27	1,5	90	22	20	16	25,5	2	114 272	144 272
M 27	1	90	22	20	16	26	2	114 273	144 273
M 28	2	90	22	20	16	26	2	114 281	144 281
M 28	1,5	90	22	20	16	26,5	2	114 282	144 282
M 30	2	90	22	22	18	28	2	114 301	144 301
M 30	1,5	90	22	22	18	28,5	2	114 302	144 302
M 30	1	90	22	22	18	29	2	114 303	144 303

\* kusy v sadě / pcs in set / Stck in Satz / штук в наборе

**Material:** NO; HSS  
**Provedení:** nebroušený závit  
**Závit:** pravý, levý - dle požadavku  
**Licování:** 2N

**Material:** CS; HSS  
**Execution:** non-ground thread  
**Thread:** right-hand, left-hand - on request  
**Tolerance:** 2N

**Werkstoff:** WS; HSS  
**Ausführung:** nicht geschliffenes Gewinde  
**Gewinde:** rechts, links - nach dem Anspruch  
**Toleranz:** 2N

**Material:** NO; HSS  
**Изготовлено:** нешлифованная резьба  
**Резьба:** правая, левая - по заказу  
**Подгонка:** 2N

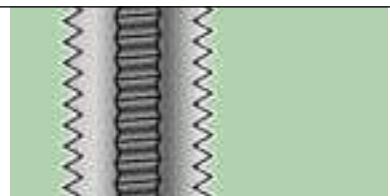



**Závitníky sadové**  
**Set of hand taps**  
**Satzgewindebohrer**  
**Метчики наборные**

**UNC**

Unifikovaný hrubý závit  
 Unified coarse thread  
 Unified-Grobgewinde  
 Унифицированная чёрная резьба

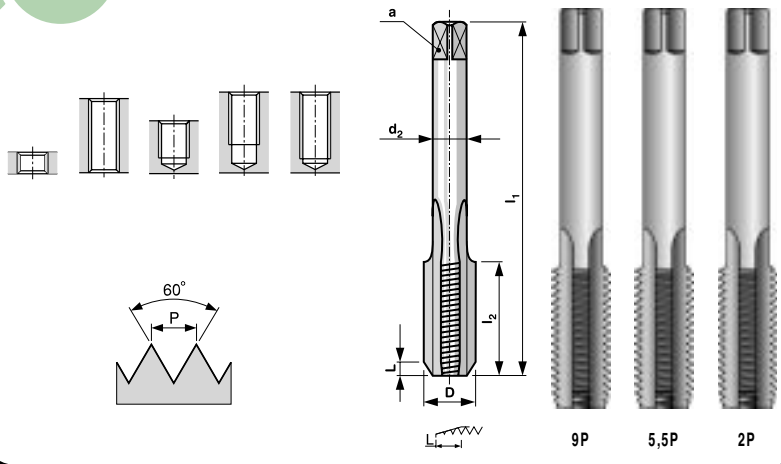

D	z/1"	P	l <sub>1</sub>	l <sub>2</sub>	d <sub>2</sub>	a		*	code NO/CS
4	40	0,635	48	11	3,15	2,5	2,3	3	115 004
5	40	0,635	48	11	3,15	2,5	2,6	3	115 005
6	32	0,794	50	13	3,55	2,8	2,85	3	115 006
8	32	0,794	53	13	4,5	3,55	3,5	3	115 008
10	24	1,058	58	16	5	4	3,9	3	115 010
12	24	1,058	62	17	5,6	4,5	4,5	3	115 012
1/4	20	1,270	66	19	6,3	5	5,1	3	115 140
5/16	18	1,411	72	22	8	6,3	6,6	3	115 516
3/8	16	1,588	78	24	10	8	8,0	3	115 380
7/16	14	1,814	85	25	8	6,3	9,4	3	115 716
1/2	13	1,954	89	29	9	7,1	10,5	3	115 120
9/16	12	2,117	95	30	11,2	9	12,0	3	115 916
5/8	11	2,309	102	32	12,5	10	13,5	3	115 580
3/4	10	2,540	112	37	14	11,2	16,5	3	115 340
7/8	9	2,822	118	38	16	12,5	19,5	3	115 780
1	8	3,175	130	45	18	14	22,25	3	115 100

\* kusy v sadě / pcs in set / Stck in Satz / штук в наборе

*Materiál: NO*  
*Provedení: nebroušený závit*  
*Licování: 2B*

*Materiál: CS*  
*Execution: non-ground thread*  
*Tolerance: 2B*

*Werkstoff: WS*  
*Ausführung: nicht geschliffenes Gewinde*  
*Toleranz: 2B*

*Материал: NO*  
*Изготовлено: нешлифованная резьба*  
*Подгонка: 2B*

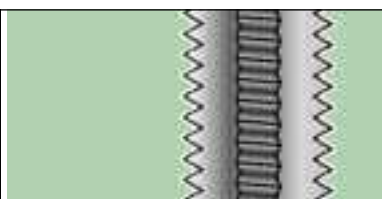

### Závitníky sadové Set of hand taps Satzgewindebohrer Метчики наборные

## UNC

Unifikovaný hrubý závit  
Unified coarse thread  
Unified-Grobgewinde  
Унифицированная чёрная резьба

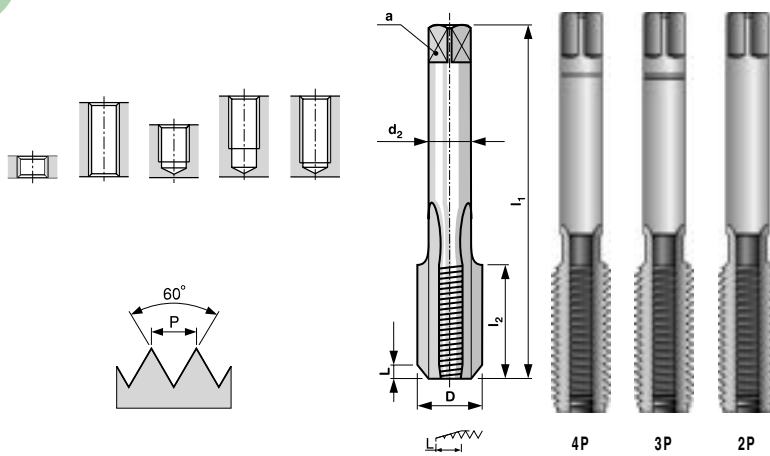

D	z/1"	P	l <sub>1</sub>	l <sub>2</sub>	d <sub>2</sub>	a		*	code HSS
4	40	0,635	40	11	3,5	2,7	2,2	3	145 004
5	40	0,635	40	11	3,5	2,7	2,6	3	145 005
6	32	0,794	45	12	4	3	2,85	3	145 006
8	32	0,794	45	13	4,5	3,4	3,5	3	145 008
10	24	1,058	50	16	6	4,9	3,9	3	145 010
12	24	1,058	50	16	6	4,9	4,5	3	145 012
1/4	20	1,270	50	19	6	4,9	5,2	3	145 140
5/16	18	1,411	53	22	6	4,9	6,6	3	145 516
3/8	16	1,588	70	24	7	5,5	8,0	3	145 380
7/16	14	1,814	70	24	8	6,2	9,4	3	145 716
1/2	13	1,954	75	28	9	7	10,75	3	145 120
9/16	12	2,117	80	30	11	9	12,25	3	145 916
5/8	11	2,309	80	32	12	9	13,5	3	145 580
3/4	10	2,540	95	34	14	11	16,5	3	145 340
7/8	9	2,822	100	34	18	14,5	19,5	3	145 780
1	8	3,175	110	38	18	14,5	22,25	3	145 100

\* kusy v sadě / pcs in set / Stck in Satz / штук в наборе

*Materiál: HSS  
Provedení: nebroušený závit  
Licování: 2B*

*Material: HSS  
Execution: non-ground thread  
Tolerance: 2B*

*Werkstoff: HSS  
Ausführung: nicht geschliffenes  
Gewinde  
Toleranz: 2B*

*Материал: HSS  
Изготовлено:  
нешлифованная резьба  
Подгонка: 2B*

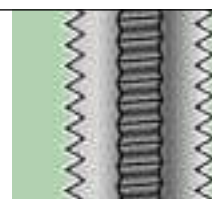

## Závitníky sadové Set of hand taps Satzgewindebohrer Метчики наборные

UNF

Unifikovaný jemný závit  
Unified fine thread  
Unified-Feingewinde  
Унифицированная мелкая резьба

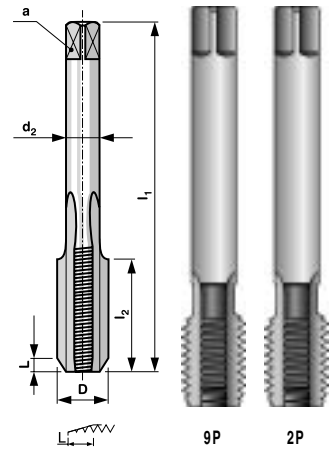
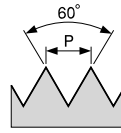
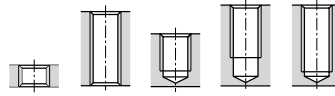

D	z/1"	P	l <sub>1</sub>	l <sub>2</sub>	d <sub>2</sub>	a		*	code NO/CS
4	48	0,529	48	11	3,15	2,5	2,4	2	116 004
5	44	0,577	48	11	3,15	2,5	2,7	2	116 005
6	40	0,635	50	13	3,55	2,8	3,0	2	116 006
8	36	0,706	53	13	4,5	3,55	3,5	2	116 008
10	32	0,794	58	16	5	4	4,1	2	116 010
12	28	0,907	62	17	5,6	4,5	4,7	2	116 012
1/4	28	0,907	66	19	6,3	5	5,5	2	116 140
5/16	24	1,058	72	22	8	6,3	6,9	2	116 516
3/8	24	1,058	78	24	10	8	8,5	2	116 380
7/16	20	1,270	82	22	8	6,3	9,9	2	116 716
1/2	20	1,270	84	24	9	7,1	11,5	2	116 120
9/16	18	1,411	90	25	11,2	9	13,0	2	116 916
5/8	18	1,411	95	25	12,5	10	14,5	2	116 580
3/4	16	1,588	104	29	14	11,2	17,5	2	116 340
7/8	14	1,814	113	33	16	12,5	20,25	2	116 780
1	12	2,117	120	35	18	14	23,25	2	116 100

\* kusy v sadě / pcs in set / Stck in Satz / штук в наборе

*Materiál: NO  
Provedení: nebroušený závit  
Licování: 2B*

*Materiál: CS  
Execution: non-ground thread  
Tolerance: 2B*

*Werkstoff: WS  
Ausführung: nicht geschliffenes  
Gewinde  
Toleranz: 2B*

*Материал: NO  
Изготовлено:  
нешлифованная резьба  
Подгонка: 2B*

### Závitníky sadové Set of hand taps Satzgewindebohrer Метчики наборные

## UNF

Unifikovaný jemný závit  
Unified fine thread  
Unified-Feingewinde  
Унифицированная мелкая резьба

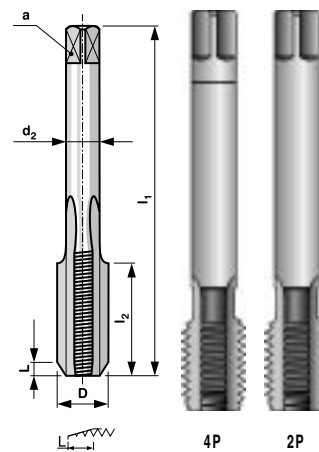
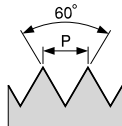
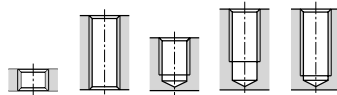

D	z/1"	P	l <sub>1</sub>	l <sub>2</sub>	d <sub>2</sub>	a		*	code HSS
5	44	0,577	40	9	3,5	2,7	2,7	2	146 005
6	40	0,635	45	10	4	3	3,0	2	146 006
8	36	0,706	45	10	4,5	3,4	3,5	2	146 008
10	32	0,794	50	12	6	4,9	4,1	2	146 010
12	28	0,907	50	12	6	4,9	4,65	2	146 012
1/4	28	0,907	50	14	6	4,9	5,5	2	146 140
5/16	24	1,058	56	22	6	4,9	6,9	2	146 516
3/8	24	1,058	63	20	7	5,5	8,5	2	146 380
7/16	20	1,270	63	20	8	6,2	9,9	2	146 716
1/2	20	1,270	70	22	9	7	11,5	2	146 120
9/16	18	1,411	70	22	11	9	12,9	2	146 916
5/8	18	1,411	70	22	12	9	14,5	2	146 580
3/4	16	1,588	80	22	14	11	17,5	2	146 340
7/8	14	1,814	80	22	18	14,5	20,5	2	146 780
1	12	2,117	80	22	18	14,5	23,25	2	146 100

\* kusy v sadě / pcs in set / Stck in Satz / штук в наборе

*Materiál: HSS  
Provedení: nebroušený závit  
Licování: 2B*

*Material: HSS  
Execution: non-ground thread  
Tolerance: 2B*

*Werkstoff: HSS  
Ausführung: nicht geschliffenes  
Gewinde  
Toleranz: 2B*

*Материал: HSS  
Изготовлено:  
нешлифованная резьба  
Подгонка: 2B*

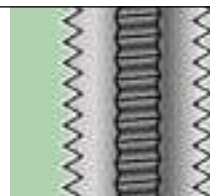

Závítníky maticové a strojní / Nut and machine taps / Muttergewindebohrer und Maschinengewindebohrer / Гаечные и механические метчики

Norma Standard Norm Стандарт	MATERIÁL / MATERIAL / MATERIAL / МАТЕРИАЛ													
	MAT	A	B	C	D	E	F	G	H	I	J	K	L	M
ČSN 22 3062	NO/CS	●								○	○		○	
	HSS	●	●			●				●	●		●	
ČSN 22 3064	NO/CS	●								○	○		○	
	HSS	●	●			●				●	●		●	
ČSN 22 3070	NO/CS	●								○	○		○	
	HSS	●	●			●				●	●		●	
ČSN 22 3074	HSS	●			○					○	○		○	
	NO/CS	●	●			●				●	●		●	
PN 8/1371	HSS	●	●	●	●	●	●	●	●	●	●	●	●	●
	HSSE	●	●	●	●	●	●	●	●	●	●	●	●	●
PN 8/1374	HSS	●	●	●	●	●	●	●	●	●	●	●	●	●
	HSSE	●	●	●	●	●	●	●	●	●	●	●	●	●
PN 8/1376	HSS	●	●	●	●	●	●	●	●	●	●	●	●	●
	HSSE	●	●	●	●	●	●	●	●	●	●	●	●	●
ČSN 22 3042	HSS	●	●	●	●	●	●	●	●	●	●	●	●	●
	HSSE	●	●	●	●	●	●	●	●	●	●	●	●	●
ČSN 22 3043	HSS	●	●		○					●	●		●	
	HSSE	●	●		○					●	●		●	
PN 8/3044	HSS	●	●	●	●	●	●	●	●	●	●	●	●	●
	HSSE	●	●	●	●	●	●	●	●	●	●	●	●	●
PN 8/3016	HSS	●			○								○	
V <sub>c</sub> m/min	NO/CS	6-10	5-8	2-6	2-6	2-4	2-6	2-4	5-8	6-10	12-18	5-8	10-15	10-15
	HSS	6-10	5-8	2-6	2-6	2-4	2-6	2-4	5-8	6-10	12-18	5-8	10-15	10-15
	HSSE	4-7								4-7	8-12		5-10	
💧		1	1	1	1	1	1	1	1, 3	1, 3	1, 3	1, 3	2, 3	3

	INFORMACE - SYMBOLY	INFORMATION - NOTATION	INFORMATIONEN - BILDERE	ИНФОРМАЦИИ - СИМВОЛЫ
NO/CS/WS	nástrojová ocel	Tool steel	Werkzeustahl	Инструментальная сталь
HSS	výkonná rychlořezná ocel	High speed steel	Schnellschneidstahl	Сталь скоростной нарезки
HSSE	vysoce výkoná rychlořezná ocel	Super high speed steel	Höher legiertet Schnellschneidstahl	Сверх производительная быстрорежущая сталь
ČSN	česká norma	Czech standard	Tschechische Norm	Чешский стандарт
PN	podniková norma	Company standard	Betriebsnorm	Стандарт общефабричный
LH	levý závit	Left-hand thread	Gewinde links	Резьба левая
TiN	povlak nitridu titanu	Titanium nitride coating	Titannitrid-Beschichtung	TiN покрытие
N	nitridace	Nitration	Nitrieren	Нитридование
OX	oxidace	Oxidation	Oxidation	Оксидирование
V <sub>c</sub>	řezná rychlost	Cutting speed	Schnittgeschwindigkeit	Скорость нарезки резьбы
💧	řezná kapalina	Cutting lubrication	Schneidflüssigkeit	Рекомендуемая жидкость
S	počet třískových otvorů	Number of clearance holes	Anzahl Spanlöcher	Количество зубьев в плашке
VA	na nerez	Stainless steel	Rostfreistähle	Нержавеющая сталь

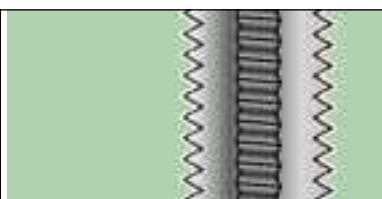

## Závitníky maticové Nut taps Muttergewindebohrer Метчики гаечные

M

Metrický závit  
Standard metric thread  
Metrische Regelgewinde  
Метрическая резьба

MF

Jemný metrický závit  
Fine metric thread  
Metrische Feingewinde  
Мелкая метрическая резьба

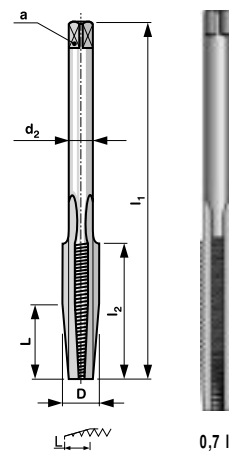
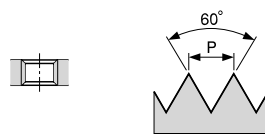

D	P	l <sub>1</sub>	l <sub>2</sub>	d <sub>2</sub>		a	code NO/CS
M 5	0,8	70	28	3,55	4,2	2,8	117 050
M 5,5	0,5	63	24	4,0	5,0	3,15	117 055
M 6	1	80	32	4,7	5,0	3,55	117 060
M 7	1	80	32	5,6	6,0	4,5	117 070
M 8	1,25	90	38	6,3	6,8	5	117 080
M 8	1	80	32	6,3	7,0	5	117 081
M 9	1,25	100	38	7,1	7,8	5,6	117 090
M 10	1,5	110	45	7,1	8,5	5,6	117 100
M 10	0,75	90	30	7,1	9,2	5,6	117 103
M 12	1,75	125	50	9	10,2	7,1	117 120
M 14	2	140	60	11,2	12,0	9	117 140
M 16	2	140	60	12,5	14,0	10	117 160
M 18	2,5	160	70	14	15,5	11,2	117 180
M 20	2,5	160	70	14	17,5	11,2	117 200
M 22	2,5	180	70	16	19,5	12,5	117 220
M 24	3	180	85	18	21,0	14	117 240

*Materiál: NO  
Provedení: nebroušený závit  
Závit: pravý, levý - dle požadavku  
Licování: 2N*

*Material: CS  
Execution: non-ground thread  
Thread: right-hand, left-hand - on request  
Tolerance: 2N*

*Werkstoff: WS  
Ausführung: nicht geschliffenes Gewinde  
Gewinde: rechts, links - nach dem Anspruch  
Toleranz: 2N*

*Material: NO  
Изготовлено: нешлифованная резьба  
Резьба: правая, левая - по заказу  
Подгонка: 2N*

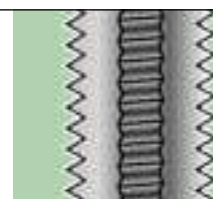

NO

CS

HSS



**BUČOVICE  
TOOLS**

## Závitníky maticové Nut taps Muttergewindebohrer Метчики гаечные

M

Metrický závit  
Standard metric thread  
Metrische Regelgewinde  
Метрическая резьба

MF

Jemný metrický závit  
Fine metric thread  
Metrische Feingewinde  
Мелкая метрическая резьба

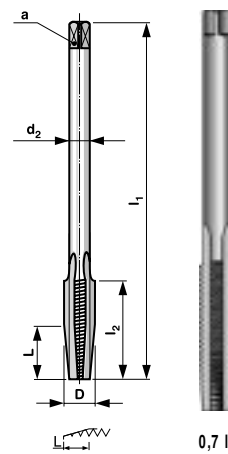
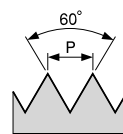

D	P	l <sub>1</sub>	l <sub>2</sub>	d <sub>2</sub>		a	code NO/CS	code HSS
M 3	0,5	48	13	2,24	2,5	-	118 030	148 030
M 3,5	0,6	52	15	2,5	2,9	-	118 035	148 035
M 4	0,7	58	18	2,8	3,3	-	118 040	148 040
M 5	0,8	70	20	3,55	4,2	2,8	118 050	148 050
M 6	1	80	25	4,7	5,0	3,55	118 060	148 060
M 7	1	80	25	5,6	6,0	4,5	118 070	148 070
M 7	0,75	70	20	5,6	6,2	4,5	118 071	148 071
M 8	1,25	90	30	6,3	6,8	5	118 080	148 080
M 8	1	80	25	6,3	7,0	5	118 081	148 081
M 10	1,5	110	35	7,1	8,5	5,6	118 100	148 100
M 10	1,25	90	30	7,1	8,8	5,6	118 101	148 101
M 10	1	90	25	7,1	9,0	5,6	118 102	148 102
M 12	1,75	125	43	9	10,2	7,1	118 120	148 120
M 12	1,5	110	35	9	10,5	7,1	118 121	148 121
M 12	1,25	110	30	9	10,8	7,1	118 122	148 122
M 12	1	110	25	9	11,0	7,1	118 123	148 123
M 14	2	140	50	11,2	12,0	9	118 140	148 140
M 14	1,5	110	35	11,2	12,5	9	118 141	148 141
M 16	2	140	50	12,5	14,0	10	118 160	148 160
M 16	1,5	125	35	12,5	14,5	10	118 161	148 161
M 18	2,5	160	60	14	15,5	11,5	118 180	148 180
M 18	1,5	125	35	14	16,5	11,2	118 181	148 181
M 20	2,5	160	60	14	17,5	11,2	118 200	148 200
M 20	1,5	140	35	14	18,5	11,2	118 201	148 201

*Materiál: NO; HSS  
Provedení: nebroušený závit  
Závit: pravý, levý - dle požadavku  
Licování: 2N*

*Material: CS; HSS  
Execution: non-ground thread  
Thread: right-hand, left-hand - on request  
Tolerance: 2N*

*Werkstoff: WS; HSS  
Ausführung: nicht geschliffenes Gewinde  
Gewinde: rechts, links - nach dem Anspruch  
Toleranz: 2N*

*Материал: NO; HSS  
Изготовлено: нешлифованная резьба  
Резьба: правая, левая - по заказу  
Подгонка: 2N*

## Závitníky maticové Nut taps Muttergewindebohrer Метчики гаечные

M

Metrický závit  
Standard metric thread  
Metrische Regelgewinde  
Метрическая резьба

MF

Jemný metrický závit  
Fine metric thread  
Metrische Feingewinde  
Мелкая метрическая резьба

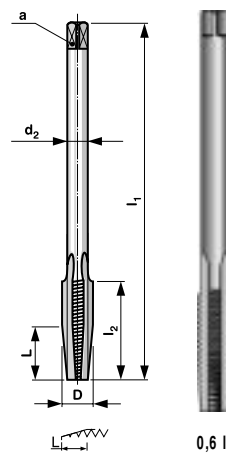
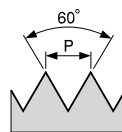

D	P	l <sub>1</sub>	l <sub>2</sub>	d <sub>2</sub>		a	code NO/CS	code HSS
M 2	0,4	60	8	1,4	1,6	-	119 020	149 020
M 2,2	0,45	60	9	1,6	1,75	-	119 022	149 022
M 2,5	0,45	60	9	1,8	2,05	-	119 025	149 025
M 2,5	0,35	60	7	1,8	2,15	-	119 026	149 026
M 3	0,5	70	10	2,24	2,5	-	119 030	149 030
M 3	0,35	70	7	2,24	2,65	-	119 031	149 031
M 3,5	0,6	80	12	2,5	2,9	-	119 035	149 035
M 3,5	0,35	80	7	2,5	3,15	-	119 036	149 036
M 4	0,7	90	14	2,8	3,3	-	119 040	149 040
M 4	0,5	90	10	2,8	3,5	-	119 041	149 041
M 4,5	0,5	100	10	3,15	4,0	-	119 045	149 045
M 5	0,8	110	16	3,55	4,2	2,8	119 050	149 050
M 5	0,5	110	10	3,55	4,5	2,8	119 051	149 051
M 5,5	0,5	110	10	4,5	5,0	3,55	119 055	149 055
M 6	1	120	20	4,5	5,0	3,55	119 060	149 060
M 6	0,75	120	16	4,5	5,5	3,55	119 061	149 061
M 7	1	120	20	5,6	6,0	4,5	119 070	149 070
M 7	0,75	120	16	5,6	6,2	4,5	119 071	149 071
M 8	1,25	140	25	6,3	6,8	5	119 080	149 080
M 8	1	140	20	6,3	7,0	5	119 081	149 081
M 8	0,75	140	16	6,3	7,2	5	119 082	149 082
M 9	1	140	20	7,1	8,0	5,6	119 090	149 090
M 10	1,5	160	30	8	8,5	6,3	119 100	149 100
M 10	1,25	160	25	8	8,8	6,3	119 101	149 101
M 10	1	160	20	8	9,0	6,3	119 102	149 102
M 12	1,75	180	36	9	10,2	7,1	119 120	149 120
M 12	1,5	180	30	9	10,8	7,1	119 121	149 121
M 12	1,25	180	25	9	11,0	7,1	119 122	149 122
M 14	2	180	40	10	12,0	8	119 140	149 140
M 14	1,5	180	30	10	12,5	8	119 141	149 141
M 14	1,25	180	25	10	12,8	8	119 142	149 142
M 16	2	200	40	12,5	14,0	10	119 160	149 160
M 16	1,5	200	30	12,5	14,5	10	119 161	149 161
M 18	2,5	200	50	14	15,5	11,2	119 180	149 180
M 18	1,5	200	30	14	16,5	11,2	119 181	149 181
M 20	2,5	220	50	16	17,5	12,5	119 200	149 200
M 20	1,5	220	30	16	18,5	12,5	119 201	149 201
M 22	2,5	220	50	18	19,5	14	119 220	149 220
M 22	1,5	220	30	18	20,5	14	119 221	149 221
M 24	3	250	60	18	21,0	14	119 240	149 240
M 24	2	250	40	18	22,0	14	119 241	149 241
M 24	1,5	250	30	18	22,5	14	119 242	149 242

Materiál: NO; HSS  
Provedení: nebroušený závit  
Závit: pravý, levý - dle požadavku  
Licování: 2N

Material: CS; HSS  
Execution: non-ground thread  
Thread: right-hand, left-hand - on request  
Tolerance: 2N

Werkstoff: WS; HSS  
Ausführung: nicht geschliffenes Gewinde  
Gewinde: rechts, links - nach dem Anspruch  
Toleranz: 2N

Material: NO; HSS  
Изготовлено: нешлифованная резьба  
Резьба: правая, левая - по заказу  
Подгонка: 2N

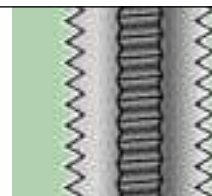



## Závitníky maticové Nut taps Muttergewindebohrer Метчики гаечные

G

Trubkový závit  
Pipe thread  
Rohrgewinde  
Трубная резьба

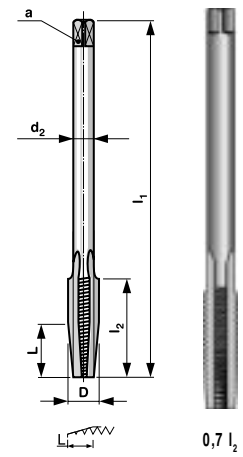
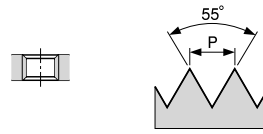

D	z/1"	P	l <sub>1</sub>	l <sub>2</sub>	d <sub>2</sub>	a		code NO/CS
G 1/16"	28	0,907	140	20	5,6	6,7	4,5	139 116
G 1/8"	28	0,907	140	20	8	8,8	6,3	139 180
G 1/4"	19	1,337	180	30	10	11,7	8	139 140
G 3/8"	19	1,337	200	30	12,5	15,2	10	139 380
G 1/2"	14	1,814	220	40	14	18,8	12,5	139 120
G 5/8"	14	1,814	220	40	18	20,75	14	139 580

*Materiál: NO  
Provedení: nebroušený závit  
Závit: pravý  
Licování: A*

*Materiál: CS  
Execution: non-ground thread  
Thread: right-hand  
Tolerance: A*

*Werkstoff: WS  
Ausführung: nicht geschliffenes  
Gewinde  
Gewinde: rechts  
Toleranz: A*

*Материал: NO  
Изготовлено: нешлифованная резьба  
Резьба: правая  
Подгонка: A*

# PN 8/3016

HSS

## Závitové bity Screwdriver-bits Gewindebohrer-Bits Метчики с шестигранным держак

M

Metrický závit  
Standard metric thread  
Metrische Regelgewinde  
Метрическая резьба

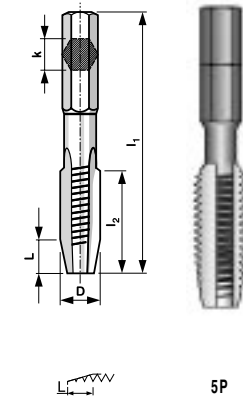
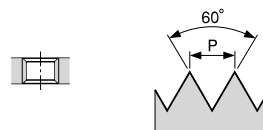

D	P	l <sub>1</sub>	l <sub>2</sub>		k	code HSS
M 3	0,5	40	13	2,5	1/4"	940 030
M 4	0,7	40	12	3,3	1/4"	940 040
M 5	0,8	40	11,5	4,2	1/4"	940 050
M 6	1	40	11	5	1/4"	940 060
M 8	1,25	40	17	6,8	1/4"	940 080
M 10	1,5	40	15	8,5	1/4"	940 100
M 12	1,75	40	15	10,2	1/4"	940 120

*Materiál: HSS  
Provedení: nebroušený závit  
Závit: pravý  
Licování: 2N*

*Materiál: HSS  
Execution: non-ground thread  
Thread: right-hand  
Tolerance: 2N*

*Werkstoff: HSS  
Ausführung: nicht geschliffenes  
Gewinde  
Gewinde: rechts  
Toleranz: 2N*

*Материал: HSS  
Изготовлено: нешлифованная резьба  
Резьба: правая  
Подгонка: 2N*

**PN 8/1371** (DIN 371)

**HSS HSSE**

**BUČOVICE TOOLS**

**Strojní závitníky**

s přímou drážkou

**Machine taps**

with straight flute

**Maschinen-Gewindebohrer**

mit gerade Nuten

**Механические метчики**

с прямой канавкой

**M**

Metrický závit  
Standard metric thread  
Metrische Regelgewinde  
Метрическая резьба

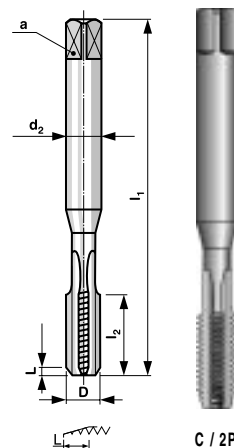
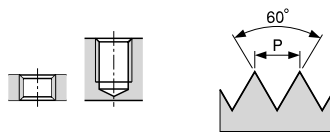

D	P	l <sub>1</sub>	l <sub>2</sub>	d <sub>2</sub>	a		code HSS	code HSSE
M 2	0,4	1,45	8	2,8	2,1	1,6	101 020	191 020
M 3	0,5	56	11	3,5	2,7	2,5	101 030	191 030
M 4	0,7	63	13	4,5	3,4	3,3	101 040	191 040
M 5	0,8	70	16	6,0	4,9	4,2	101 050	191 050
M 6	1	80	19	6,0	4,9	5	101 060	191 060
M 8	1,25	90	22	8,0	6,2	6,3	101 080	191 080
M 10	1,5	100	24	10,0	8,0	8,5	101 100	191 100

*Material: HSS; HSSE  
Provedení: nebroušený závit  
Závit: pravý  
Licování: 2N*

*Material: HSS; HSSE  
Execution: non-ground thread  
Thread: right-hand  
Tolerance: 2N*

*Werkstoff: HSS; HSSE  
Ausführung: nicht geschliffenes  
Gewinde  
Gewinde: rechts  
Toleranz: 2N*

*Material: HSS; HSSE  
Изготовлено:  
нешлифованная резьба  
Резьба: правая  
Подгонка: 2N*

**PN 8/1371** (DIN 371)

**HSS HSSE**

**BUČOVICE TOOLS**

**Strojní závitníky**

přímá drážka s lamačem třísek

**Machine taps**

with spiral point

**Maschinen-Gewindebohrer**

mit Schälanschnitt

**Механические метчики**

с ломателем стружек

**M**

Metrický závit  
Standard metric thread  
Metrische Regelgewinde  
Метрическая резьба

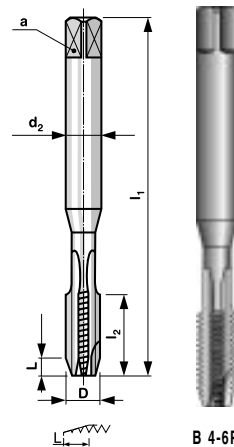
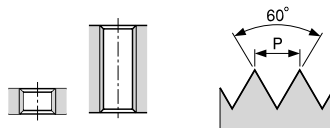

D	P	l <sub>1</sub>	l <sub>2</sub>	d <sub>2</sub>	a		code HSS	code HSSE
M 3	0,5	56	11	3,5	2,7	2,5	102 030	192 030
M 4	0,7	63	13	4,5	3,4	3,3	102 040	192 040
M 5	0,8	70	16	6,0	4,9	4,2	102 050	192 050
M 6	1	80	19	6,0	4,9	5	102 060	192 060
M 8	1,25	90	22	8,0	6,2	6,3	102 080	192 080
M 10	1,5	100	24	10,0	8,0	8,5	102 100	192 100

*Material: HSS; HSSE  
Provedení: nebroušený závit  
Závit: pravý  
Licování: 2N*

*Material: HSS; HSSE  
Execution: non-ground thread  
Thread: right-hand  
Tolerance: 2N*

*Werkstoff: HSS; HSSE  
Ausführung: nicht geschliffenes  
Gewinde  
Gewinde: rechts  
Toleranz: 2N*

*Material: HSS; HSSE  
Изготовлено:  
нешлифованная резьба  
Резьба: правая  
Подгонка: 2N*

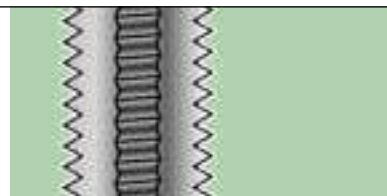

**Strojní závitníky**  
se šroubovitými drážkami 35°

**Machine taps**  
with spiral flute 35°

**Maschinen-Gewindebohrer**

mit Rechtsspiralnute 35°

**Механические метчики**  
с винтовыми дорожками 35°

**M**

Metrický závit  
Standard metric thread  
Metrische Regelgewinde  
Метрическая резьба

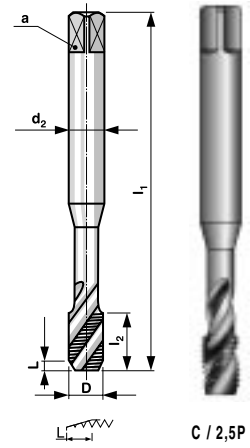
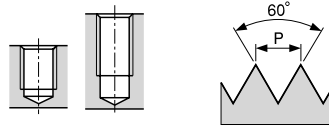

D	P	l <sub>1</sub>	l <sub>2</sub>	d <sub>2</sub>	a		code HSS	code HSSE
M 3	0,5	56	5	3,5	2,7	2,5	103 030	193 030
M 4	0,7	63	7	4,5	3,4	3,3	103 040	193 040
M 5	0,8	70	8	6,0	4,9	4,2	103 050	193 050
M 6	1	80	10	6,0	4,9	5	103 060	193 060
M 8	1,25	90	13	8,0	6,2	6,3	103 080	193 080
M 10	1,5	100	15	10,0	8,0	8,5	103 100	193 100

### Strojní závitníky

s přímou drážkou

### Machine taps

with straight flute

### Maschinen-Gewindebohrer

mit gerade Nuten

### Механические метчики

с прямой канавкой

# MF

Jemný metrický závit  
Fine metric thread  
Metrische Feingewinde  
Мелкая метрическая резьба

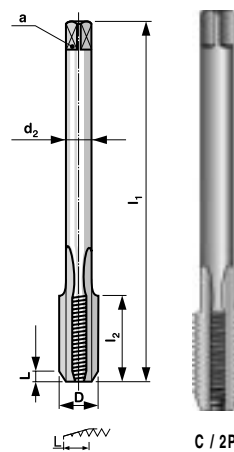
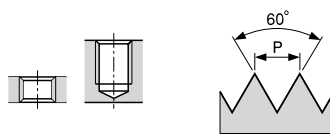

D	P	l <sub>1</sub>	l <sub>2</sub>	d <sub>2</sub>	a		code HSS
M 3	0,35	56	8	2,2	-	2,65	107 031
M 4	0,5	63	10	2,8	2,1	3,5	107 041
M 5	0,5	70	12	3,5	2,7	4,5	107 051
M 6	0,75	80	14	4,5	3,4	5,2	107 061
M 6	0,5	80	14	4,5	3,4	5,5	107 062
M 8	1	90	22	6,0	4,9	7,0	107 081
M 8	0,75	80	18	6,0	4,9	7,2	107 082
M 10	1,25	100	24	7,0	5,5	8,3	107 101
M 10	1	90	20	7,0	5,5	9,0	107 102
M 10	0,75	90	20	7,0	5,5	9,2	107 103
M 12	1,5	100	22	9,0	7,0	10,5	107 121
M 12	1,25	100	22	9,0	7,0	10,3	107 122
M 12	1	100	22	9,0	7,0	11,0	107 123
M 14	1,5	100	22	11,0	9,0	12,5	107 141
M 14	1,25	100	22	11,0	9,0	12,8	107 142
M 14	1	100	22	11,0	9,0	13,0	107 143
M 16	1,5	100	22	12,0	9,0	14,5	107 161
M 16	1	100	22	12,0	9,0	15,0	107 162
M 18	1,5	110	25	14,0	11,0	16,5	107 181
M 18	1	110	25	14,0	11,0	17,0	107 182
M 20	1,5	125	25	16,0	12,0	18,5	107 201
M 20	1	125	25	16,0	12,0	19,0	107 202
M 22	1,5	125	25	18,0	14,5	20,5	107 221
M 22	1	125	25	18,0	14,5	21,0	107 222
M 24	2	140	28	18,0	14,5	22,0	107 241
M 24	1,5	140	28	18,0	14,5	22,5	107 242
M 24	1	140	28	18,0	14,5	23,0	107 243
M 25	1,5	140	28	18,0	14,5	23,5	107 251
M 26	1,5	140	28	18,0	14,5	24,5	107 261
M 27	2	140	28	20,0	16,0	25,0	107 271
M 27	1,5	140	28	20,0	16,0	25,5	107 272
M 27	1	140	28	20,0	16,0	26,0	107 273
M 28	1,5	140	28	20,0	16,0	26,5	107 281
M 30	2	150	28	22,0	18,0	28,0	107 301
M 30	1,5	150	28	22,0	18,0	28,5	107 302
M 30	1	150	28	22,0	18,0	29,0	107 303

*Material: HSS  
Provedení: nebroušený závit  
Závit: pravý  
Licování: 2N*

*Material: HSS  
Execution: non-ground thread  
Thread: right-hand  
Tolerance: 2N*

*Werkstoff: HSS  
Ausführung: nicht geschliffenes  
Gewinde  
Gewinde: rechts  
Toleranz: 2N*

*Material: HSS  
Изготовлено: нешлифованная резьба  
Резьба: правая  
Подгонка: 2N*

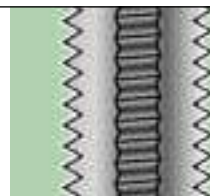

### Strojní závitníky přímá drážka s lamačem třísek

Machine taps  
with spiral point

Maschinen-Gewinde-  
bohrer

mit Schälanschnitt

Механические метчики

с ломателем стружек

## MF

Jemný metrický závit  
Fine metric thread  
Metrische Feingewinde  
Мелкая метрическая резьба

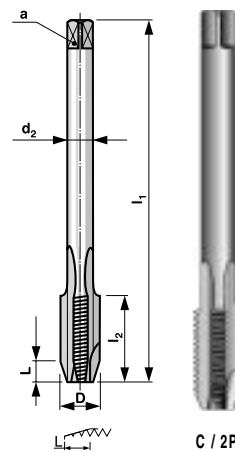
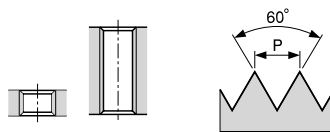

D	P	l <sub>1</sub>	l <sub>2</sub>	d <sub>2</sub>	a		code HSS
M 3	0,35	56	8	2,2	-	2,65	108 031
M 4	0,5	63	10	2,8	2,1	3,5	108 041
M 5	0,5	70	12	3,5	2,7	4,5	108 051
M 6	0,75	80	14	4,5	3,4	5,2	108 061
M 6	0,5	80	14	4,5	3,4	5,5	108 062
M 8	1	90	22	6,0	4,9	7,0	108 081
M 8	0,75	80	18	6,0	4,9	7,2	108 082
M 10	1,25	100	24	7,0	5,5	8,3	108 101
M 10	1	90	20	7,0	5,5	9,0	108 102
M 10	0,75	90	20	7,0	5,5	9,2	108 103
M 12	1,5	100	22	9,0	7,0	10,5	108 121
M 12	1,25	100	22	9,0	7,0	10,3	108 122
M 12	1	100	22	9,0	7,0	11,0	108 123
M 14	1,5	100	22	11,0	9,0	12,5	108 141
M 14	1,25	100	22	11,0	9,0	12,8	108 142
M 14	1	100	22	11,0	9,0	13,0	108 143
M 16	1,5	100	22	12,0	9,0	14,5	108 161
M 16	1	100	22	12,0	9,0	15,0	108 162
M 18	1,5	110	25	14,0	11,0	16,5	108 181
M 18	1	110	25	14,0	11,0	17,0	108 182
M 20	1,5	125	25	16,0	12,0	18,5	108 201
M 20	1	125	25	16,0	12,0	19,0	108 202
M 22	1,5	125	25	18,0	14,5	20,5	108 221
M 22	1	125	25	18,0	14,5	21,0	108 222
M 24	2	140	28	18,0	14,5	22,0	108 241
M 24	1,5	140	28	18,0	14,5	22,5	108 242
M 24	1	140	28	18,0	14,5	23,0	108 243
M 25	1,5	140	28	18,0	14,5	23,5	108 251
M 26	1,5	140	28	18,0	14,5	24,5	108 261
M 27	2	140	28	20,0	16,0	25,0	108 271
M 27	1,5	140	28	20,0	16,0	25,5	108 272
M 27	1	140	28	20,0	16,0	26,0	108 273
M 28	1,5	140	28	20,0	16,0	26,5	108 281
M 30	2	150	28	22,0	18,0	28,0	108 301
M 30	1,5	150	28	22,0	18,0	28,5	108 302
M 30	1	150	28	22,0	18,0	29,0	108 303

*Materiál: HSS  
Provedení: nebroušený závit  
Závit: pravý  
Licování: 2N*

*Material: HSS  
Execution: non-ground thread  
Thread: right-hand  
Tolerance: 2N*

*Werkstoff: HSS  
Ausführung: nicht geschliffenes  
Gewinde  
Gewinde: rechts  
Toleranz: 2N*

*Материал: HSS  
Изготовлено:  
нешлифованная резьба  
Резьба: правая  
Подгонка: 2N*

### Strojní závitníky se šroubovitými drážkami 35°

**Machine taps**  
with spiral flute 35°

**Maschinen-Gewinde-  
bohrer**

mit Rechtsspiralnute 35°

**Механические метчики**  
с винтовыми дорожками 35°

**MF**

Jemný metrický závit  
Fine metric thread  
Metrische Feingewinde  
Мелкая метрическая резьба

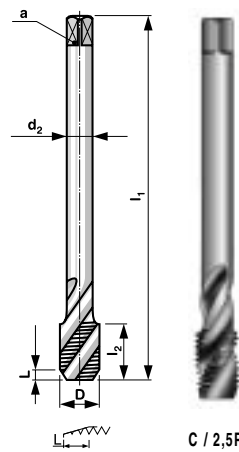
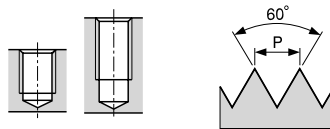

D	P	l <sub>1</sub>	l <sub>2</sub>	d <sub>2</sub>	a		code HSS
M 3	0,35	56	8	2,2	-	2,65	109 031
M 4	0,5	63	10	2,8	2,1	3,5	109 041
M 5	0,5	70	12	3,5	2,7	4,5	109 051
M 6	0,75	80	14	4,5	3,4	5,2	109 061
M 6	0,5	80	14	4,5	3,4	5,5	109 062
M 8	1	90	22	6,0	4,9	7,0	109 081
M 8	0,75	80	18	6,0	4,9	7,2	109 082
M 10	1,25	100	24	7,0	5,5	8,3	109 101
M 10	1	90	20	7,0	5,5	9,0	109 102
M 10	0,75	90	20	7,0	5,5	9,2	109 103
M 12	1,5	100	22	9,0	7,0	10,5	109 121
M 12	1,25	100	22	9,0	7,0	10,3	109 122
M 12	1	100	22	9,0	7,0	11,0	109 123
M 14	1,5	100	22	11,0	9,0	12,5	109 141
M 14	1,25	100	22	11,0	9,0	12,8	109 142
M 14	1	100	22	11,0	9,0	13,0	109 143
M 16	1,5	100	22	12,0	9,0	14,5	109 161
M 16	1	100	22	12,0	9,0	15,0	109 162
M 18	1,5	110	25	14,0	11,0	16,5	109 181
M 18	1	110	25	14,0	11,0	17,0	109 182
M 20	1,5	125	25	16,0	12,0	18,5	109 201
M 20	1	125	25	16,0	12,0	19,0	109 202
M 22	1,5	125	25	18,0	14,5	20,5	109 221
M 22	1	125	25	18,0	14,5	21,0	109 222
M 24	2	140	28	18,0	14,5	22,0	109 241
M 24	1,5	140	28	18,0	14,5	22,5	109 242
M 24	1	140	28	18,0	14,5	23,0	109 243
M 25	1,5	140	28	18,0	14,5	23,5	109 251
M 26	1,5	140	28	18,0	14,5	24,5	109 261
M 27	2	140	28	20,0	16,0	25,0	109 271
M 27	1,5	140	28	20,0	16,0	25,5	109 272
M 27	1	140	28	20,0	16,0	26,0	109 273
M 28	1,5	140	28	20,0	16,0	26,5	109 281
M 30	2	150	28	22,0	18,0	28,0	109 301
M 30	1,5	150	28	22,0	18,0	28,5	109 302
M 30	1	150	28	22,0	18,0	29,0	109 303

*Materiál: HSS  
Provedení: nebroušený závit  
Závit: pravý  
Licování: 2N*

*Material: HSS  
Execution: non-ground thread  
Thread: right-hand  
Tolerance: 2N*

*Werkstoff: HSS  
Ausführung: nicht geschliffenes  
Gewinde  
Gewinde: rechts  
Toleranz: 2N*

*Материал: HSS  
Изготовлено:  
нешлифованная резьба  
Резьба: правая  
Подгонка: 2N*

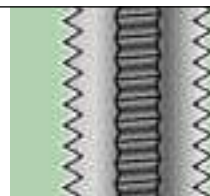

## Strojní závitníky

s přímou drážkou

## Machine taps

with straight flute

## Maschinen-Gewindebohrer

mit gerade Nuten

## Механические метчики

с прямой канавкой

M

Metrický závit  
Standard metric thread  
Metrische Regelgewinde  
Метрическая резьба

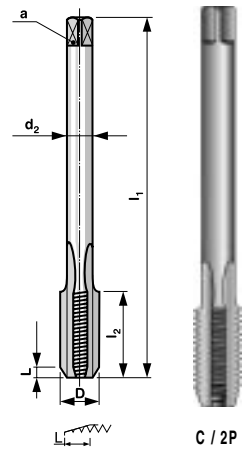
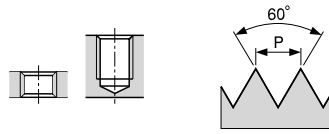

D	P	l <sub>1</sub>	l <sub>2</sub>	d <sub>2</sub>	a		code HSS	code HSSE
M 3	0,5	56	11	2,2	-	2,5	104 030	194 030
M 4	0,7	63	13	2,8	2,1	3,3	104 040	194 040
M 5	0,8	70	16	3,5	2,7	4,2	104 050	194 050
M 6	1	80	19	4,5	3,4	5,0	104 060	194 060
M 8	1,25	90	22	6,0	4,9	6,8	104 080	194 080
M 10	1,5	100	24	7,0	5,5	8,5	104 100	194 100
M 12	1,75	110	28	9,0	7,0	10,2	104 120	194 120
M 14	2	110	30	11,0	9,0	12,0	104 140	194 140
M 16	2	110	32	12,0	9,0	14,0	104 160	194 160
M 18	2,5	125	34	14,0	11,0	15,5	104 180	194 180
M 20	2,5	140	34	16,0	12,0	17,5	104 200	194 200
M 22	2,5	140	34	18,0	14,5	19,5	104 220	194 220
M 24	3	160	38	18,0	14,5	21,0	104 240	194 240
M 27	3	160	38	20,0	16,0	24,0	104 270	194 270
M 30	3,5	180	45	22,0	18,0	26,5	104 300	194 300

Materiál: HSS; HSSE  
Provedení: nebroušený závit  
Závit: pravý  
Licování: 2N

Material: HSS; HSSE  
Execution: non-ground thread  
Thread: right-hand  
Tolerance: 2N

Werkstoff: HSS; HSSE  
Ausführung: nicht geschliffenes  
Gewinde  
Gewinde: rechts  
Toleranz: 2N

Материал: HSS; HSSE  
Изготовлено:  
нешлифованная резьба  
Резьба: правая  
Подгонка: 2N

### Strojní závitníky přímá drážka s lamačem třísek

**Machine taps**  
with spiral point

**Maschinen-Gewinde-  
bohrer**

mit Schälanschnitt

**Механические метчики**  
с ломателем стружек

**M**

Metrický závit  
Standard metric thread  
Metrische Regelgewinde  
Метрическая резьба

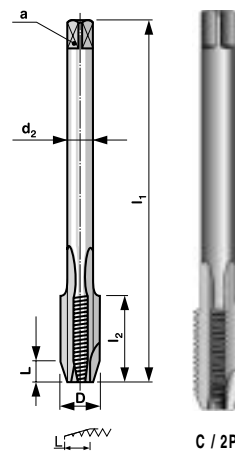
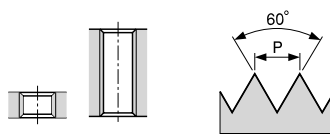

D	P	l <sub>1</sub>	l <sub>2</sub>	d <sub>2</sub>	a		code HSS	code HSSE
M 3	0,5	56	11	2,2	-	2,5	105 030	195 030
M 4	0,7	63	13	2,8	2,1	3,3	105 040	195 040
M 5	0,8	70	16	3,5	2,7	4,2	105 050	195 050
M 6	1	80	19	4,5	3,4	5,0	105 060	195 060
M 8	1,25	90	22	6,0	4,9	6,8	105 080	195 080
M 10	1,5	100	24	7,0	5,5	8,5	105 100	195 100
M 12	1,75	110	28	9,0	7,0	10,2	105 120	195 120
M 14	2	110	30	11,0	9,0	12,0	105 140	195 140
M 16	2	110	32	12,0	9,0	14,0	105 160	195 160
M 18	2,5	125	34	14,0	11,0	15,5	105 180	195 180
M 20	2,5	140	34	16,0	12,0	17,5	105 200	195 200
M 22	2,5	140	34	18,0	14,5	19,5	105 220	195 220
M 24	3	160	38	18,0	14,5	21,0	105 240	195 240
M 27	3	160	38	20,0	16,0	24,0	105 270	195 270
M 30	3,5	180	45	22,0	18,0	26,5	105 300	195 300

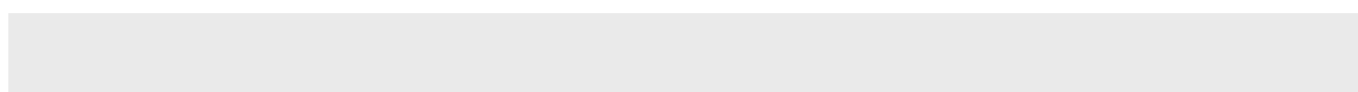
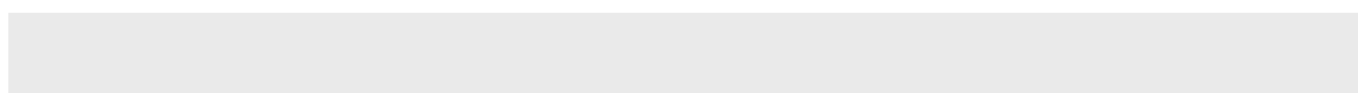
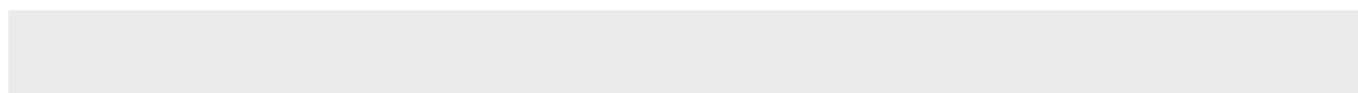
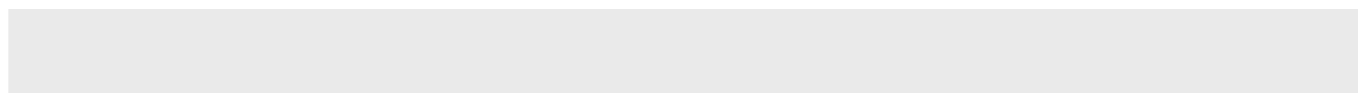
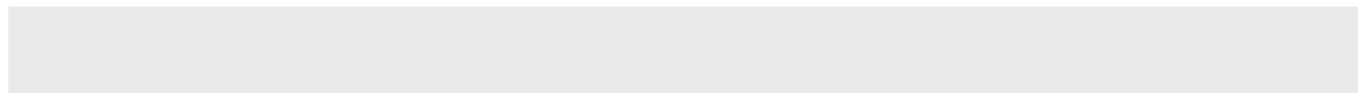
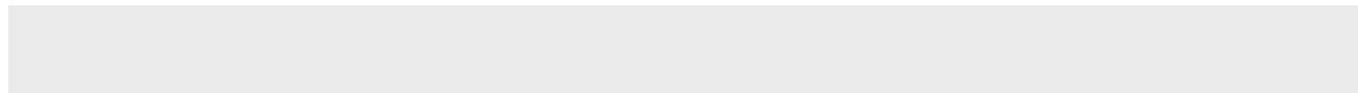

*Material: HSS; HSSE  
Provedení: nebroušený závit  
Závit: pravý  
Licování: 2N*

*Material: HSS; HSSE  
Execution: non-ground thread  
Thread: right-hand  
Tolerance: 2N*

*Werkstoff: HSS; HSSE  
Ausführung: nicht geschliffenes  
Gewinde  
Gewinde: rechts  
Toleranz: 2N*

*Material: HSS; HSSE  
Изготовлено:  
нешлифованная резьба  
Резьба: правая  
Подгонка: 2N*

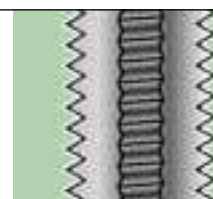



**Strojní závitníky**  
se šroubovitými drážkami 35°

**Machine taps**  
with spiral flute 35°

**Maschinen-Gewinde-  
bohrer**

mit Rechtsspiralnute 35°

**Механические метчики**  
с винтовыми дорожками 35°

**M**

Metrický závit  
Standard metric thread  
Metrische Regelgewinde  
Метрическая резьба

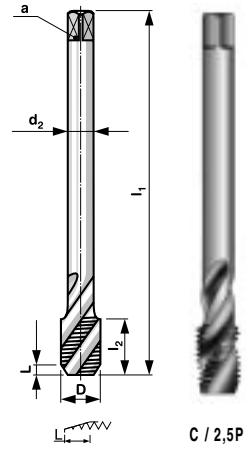
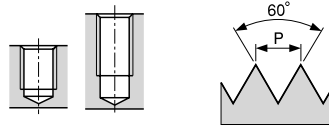

C / 2,5P

D	P	l <sub>1</sub>	l <sub>2</sub>	d <sub>2</sub>	a		code HSS	code HSSE
M 3	0,5	56	5	2,2	-	2,5	106 030	196 030
M 4	0,7	63	7	2,8	2,1	3,3	106 040	196 040
M 5	0,8	70	8	3,5	2,7	4,2	106 050	196 050
M 6	1	80	10	4,5	3,4	5,0	106 060	196 060
M 8	1,25	90	13	6,0	4,9	6,8	106 080	196 080
M 10	1,5	100	15	7,0	5,5	8,5	106 100	196 100
M 12	1,75	110	18	9,0	7,0	10,2	106 120	196 120
M 14	2	110	20	11,0	9,0	12,0	106 140	196 140
M 16	2	110	20	12,0	9,0	14,0	106 160	196 160
M 18	2,5	125	25	14,0	11,0	15,5	106 180	196 180
M 20	2,5	140	25	16,0	12,0	17,5	106 200	196 200
M 22	2,5	140	25	18,0	14,5	19,5	106 220	196 220
M 24	3	160	30	18,0	14,5	21,0	106 240	196 240
M 27	3	160	30	20,0	16,0	24,0	106 270	196 270
M 30	3,5	180	35	22,0	18,0	26,5	106 300	196 300

*Materiál: HSS; HSSE  
Provedení: nebroušený závit  
Závit: pravý  
Licování: 2N*

*Material: HSS; HSSE  
Execution: non-ground thread  
Thread: right-hand  
Tolerance: 2N*

*Werkstoff: HSS; HSSE  
Ausführung: nicht geschliffenes  
Gewinde  
Gewinde: rechts  
Toleranz: 2N*

*Материал: HSS; HSSE  
Изготовлено:  
нешлифованная резьба  
Резьба: правая  
Подгонка: 2N*

# ČSN 22 3042

HSSE



**BUČOVICE TOOLS**

## Strojní závitníky

s přímou drážkou

## Machine taps

with straight flute

## Maschinen-Gewindebohrer

mit gerade Nuten

## Механические метчики

с прямой канавкой

M

Metrický závit  
Standard metric thread  
Metrische Regelgewinde  
Метрическая резьба

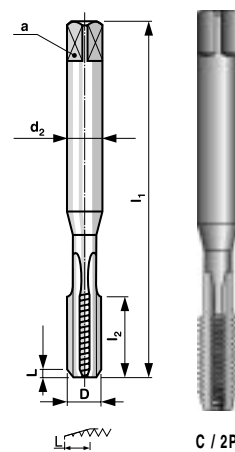
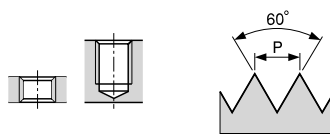

D	P	l <sub>1</sub>	l <sub>2</sub>	d <sub>2</sub>	a		code HSSE
M 3	0,5	48	11	3,15	2,5	2,5	162 030
M 4	0,7	53	13	4,0	3,15	3,3	162 040
M 5	0,8	58	16	5,0	4,0	4,2	162 050
M 6	1	66	19	6,3	5,0	5,0	162 060
M 8	1,25	72	22	8,0	6,3	6,8	162 080
M 10	1,5	80	24	10,0	8,0	8,5	162 100
M 12	1,75	89	29	9,0	7,1	10,2	162 120

*Materiál: HSSE  
Provedení: broušený závit  
Závit: pravý  
Licování: ISO1*

*Material: HSSE  
Execution: ground thread  
Thread: right-hand  
Tolerance: ISO1*

*Werkstoff: HSSE  
Ausführung: geschliffenes  
Gewinde  
Gewinde: rechts  
Toleranz: ISO1*

*Материал: HSSE  
Изготовлено: шлифованная  
резьба  
Резьба: правая  
Подгонка: ISO1*

# ČSN 22 3043

HSSE



**BUČOVICE TOOLS**

## Strojní závitníky

přímá drážka s lamačem třísek

## Machine taps

with spiral point

## Maschinen-Gewindebohrer

mit Schälanschnitt

## Механические метчики

с ломателем стружек

M

Metrický závit  
Standard metric thread  
Metrische Regelgewinde  
Метрическая резьба

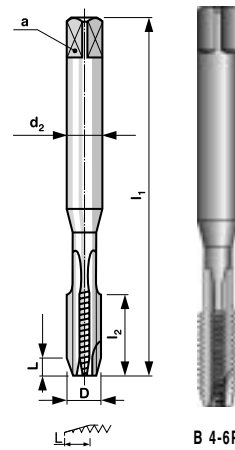
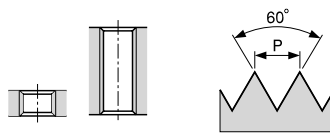

D	P	l <sub>1</sub>	l <sub>2</sub>	d <sub>2</sub>	a		code HSSE
M 3	0,5	48	11	3,15	2,5	2,5	163 030
M 4	0,7	53	13	4,0	3,15	3,3	163 040
M 5	0,8	58	16	5,0	4,0	4,2	163 050
M 6	1	66	19	6,3	5,0	5,0	163 060
M 8	1,25	72	22	8,0	6,3	6,8	163 080
M 10	1,5	80	24	10,0	8,0	8,5	163 100
M 12	1,75	89	29	9,0	7,1	10,2	163 120

*Materiál: HSSE  
Provedení: broušený závit  
Závit: pravý  
Licování: ISO1*

*Material: HSSE  
Execution: ground thread  
Thread: right-hand  
Tolerance: ISO1*

*Werkstoff: HSSE  
Ausführung: geschliffenes  
Gewinde  
Gewinde: rechts  
Toleranz: ISO1*

*Материал: HSSE  
Изготовлено: шлифованная  
резьба  
Резьба: правая  
Подгонка: ISO1*

**Strojní závitníky**  
se šroubovitými drážkami 35°

**Machine taps**  
with spiral flute 35°

**Maschinen-Gewindebohrer**

mit Rechtsspiralnute 35°

**Механические метчики**

с винтовыми дорожками 35°

# M

Metrický závit  
Standard metric thread  
Metrische Regelgewinde  
Метрическая резьба

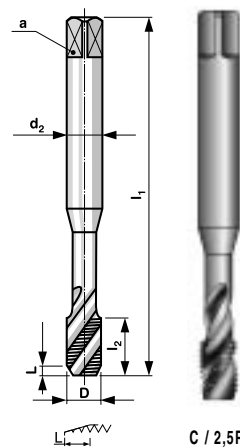
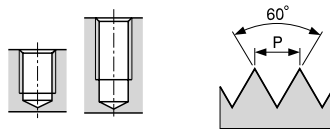

C / 2,5P

D	P	l <sub>1</sub>	l <sub>2</sub>	d <sub>2</sub>	a		code HSS
M 3	0,5	48	5,5	3,15	2,5	2,5	164 030
M 4	0,7	53	8	4,0	3,15	3,3	164 040
M 5	0,8	58	9	5,0	4,0	4,2	164 050
M 6	1	66	11	6,3	5,0	5,0	164 060
M 8	1,25	72	14	8,0	6,3	6,8	164 080
M 10	1,5	80	16	10,0	8,0	8,5	164 100
M 12	1,75	89	20	9,0	7,1	10,2	164 120

*Materiál: HSSE  
Provedení: broušený závit  
Závit: pravý  
Licování: ISO1*

*Material: HSSE  
Execution: ground thread  
Thread: right-hand  
Tolerance: ISO1*

*Werkstoff: HSSE  
Ausführung: geschliffenes  
Gewinde  
Gewinde: rechts  
Toleranz: ISO1*

*Материал: HSSE  
Изготовлено: шлифованная  
резьба  
Резьба: правая  
Подгонка: ISO1*